

LMH730277 2:1 Multiplexer Evaluation Board

General Description

The LMH™730277 evaluation board is designed to aid in the characterization of National Semiconductor's High Speed 2:1 Multiplexers.

Use the evaluation board as a guide for high frequency layout and as a tool to aid in device testing and characterization.

The evaluation board schematic is shown in *Figure 1*. Refer to the product data sheets for recommendations for component values.

Basic Operation

By changing the input termination resistors (R_{IN0} and R_{IN1}) and series output resistor (R_{OUT}) different input and output impedances can be matched. The SMA connectors and board traces are optimized for 50 to 75Ω operation. Other impedances can be matched but performance may be noticeably different, especially high frequency response. Even with optimal layout, board parasitics play a large part in high frequency performance and different termination resistors will change the frequency of the dominant parasitic poles/zeros. To accommodate 50Ω high speed pulse generators for driving the select (SEL) or shutdown (SD) pins, use the logic control signal termination resistors (R_{SEL} and R_S) to match the impedance of the signal generator. When driving the logic pins be careful to use compatible signal levels. Devices designed for split supply operation will require special care if used in a single supply configuration. See the device datasheet for more details

Layout Considerations

Printed circuit board layout and supply bypassing play major roles in determining high frequency performance. When designing your own board use the LMH730277 evaluation

board as a guide and follow these steps to optimize high frequency performance

1. Use a ground plane.
2. Include large (~6.8 μF) capacitors on both supplies (C_3 & C_4).
3. Near the device use .01 μF ceramic capacitors from both supplies to ground (C_1 , C_2).
4. A capacitor between V^+ and V^- is optional (C_5) but will help suppress second order harmonic distortion.
5. Remove the ground and power planes from under and around the part, especially near the OUT and FB pins.
6. Minimize all trace lengths.
7. Use terminated transmission lines for long traces.

Sample artwork for the LMH730277 Evaluation board is included on the next page in *Figure 2*.

Measurement Hints

The board is designed for 50Ω input and output connections into coaxial cables. For other impedances the terminating resistors can be modified to help match different impedances.

Do not use normal oscilloscope probes to test these circuits. The capacitive loading will change circuit performance drastically. Instead use low impedance resistive divider probes of 100 to 500Ω. See *Figure 3* for a sample resistive probe. The Low impedance resistor should be 50 - 450Ω. The ground connection should be as short as possible (~1/2"). Even with careful use of these probes, results should be considered preliminary until verified with controlled impedance measurements. Even the best probes will interfere with circuit operation to some degree. Also, tools, power cables, fingers, etc. near the device will change measurement results, often dramatically.

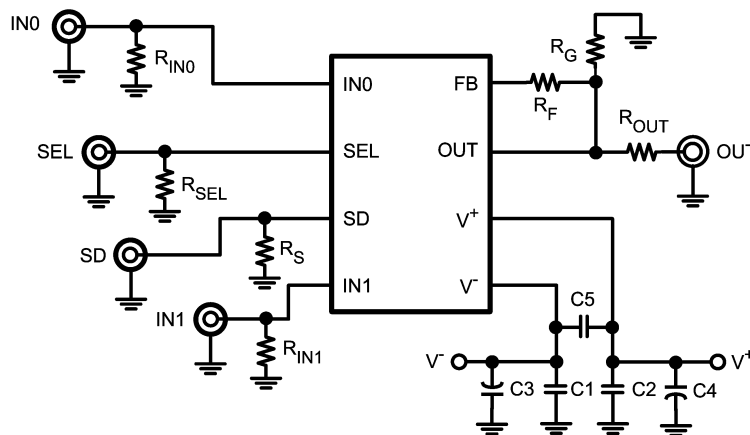

20141803

FIGURE 1. Board Schematic

LMH™ is a trademark of National Semiconductor Corporation.

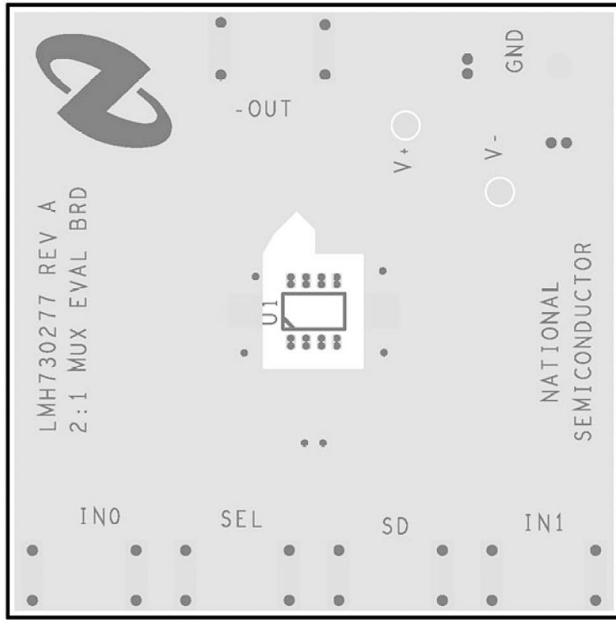

20141801

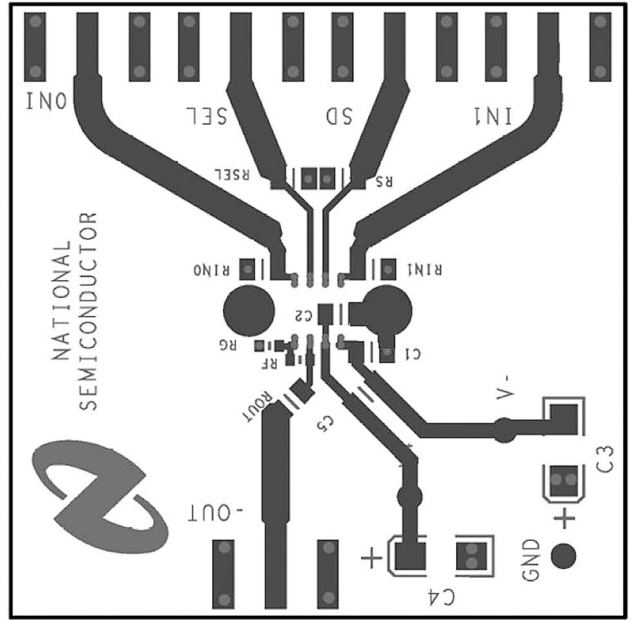

20141802

FIGURE 2. Board Layout (Actual Size = 2" x 2")

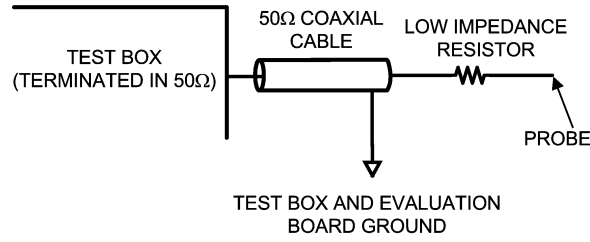

$$\text{PROBE ATTENUATION} = \frac{50}{R + 50}$$

20141804

FIGURE 3. Probe Schematic

Notes

National does not assume any responsibility for use of any circuitry described, no circuit patent licenses are implied and National reserves the right at any time without notice to change said circuitry and specifications.

For the most current product information visit us at www.national.com.

LIFE SUPPORT POLICY

NATIONAL'S PRODUCTS ARE NOT AUTHORIZED FOR USE AS CRITICAL COMPONENTS IN LIFE SUPPORT DEVICES OR SYSTEMS WITHOUT THE EXPRESS WRITTEN APPROVAL OF THE PRESIDENT AND GENERAL COUNSEL OF NATIONAL SEMICONDUCTOR CORPORATION. As used herein:

- | | |
|--|---|
| <p>1. Life support devices or systems are devices or systems which, (a) are intended for surgical implant into the body, or (b) support or sustain life, and whose failure to perform when properly used in accordance with instructions for use provided in the labeling, can be reasonably expected to result in a significant injury to the user.</p> | <p>2. A critical component is any component of a life support device or system whose failure to perform can be reasonably expected to cause the failure of the life support device or system, or to affect its safety or effectiveness.</p> |
|--|---|

BANNED SUBSTANCE COMPLIANCE

National Semiconductor manufactures products and uses packing materials that meet the provisions of the Customer Products Stewardship Specification (CSP-9-111C2) and the Banned Substances and Materials of Interest Specification (CSP-9-111S2) and contain no "Banned Substances" as defined in CSP-9-111S2.



National Semiconductor
Americas Customer
Support Center
 Email: new.feedback@nsc.com
 Tel: 1-800-272-9959

National Semiconductor
Europe Customer Support Center
 Fax: +49 (0) 180-530 85 86
 Email: europe.support@nsc.com
 Deutsch Tel: +49 (0) 69 9508 6208
 English Tel: +44 (0) 870 24 0 2171
 Français Tel: +33 (0) 1 41 91 8790

National Semiconductor
Asia Pacific Customer
Support Center
 Email: ap.support@nsc.com

National Semiconductor
Japan Customer Support Center
 Fax: 81-3-5639-7507
 Email: jpn.feedback@nsc.com
 Tel: 81-3-5639-7560